



# **Arkansas Water Resources Center**

## **AN INTRODUCTION TO LAKE AND RESERVOIR WATER QUALITY MODELING**

A Short Course Presented at the Arkansas Water Resources Center Annual  
Spring Conference March 25, 1996

Kenneth H. Reckhow, Ph.D.  
Director, Water Resources Research Institute  
University of North Carolina  
Raleigh, North Carolina

MSC-198

Arkansas Water Resources Center  
112 Ozark Hall  
University of Arkansas  
Fayetteville, Arkansas 72701

**Lake and Reservoir Water Quality Modeling**  
**Kenneth H. Reckhow**  
**March 25, 1997**

Topics

Introduction and overview; objectives and outline for lecture (questions and discussion encouraged)

2. What's the problem? What do we care about? ==> objectives and attributes
3. Assessment and prediction - scientific analysis in support of decision making ==> models
4. Model selection criteria  
  
    Mechanistic models (WASP5)
6. Bathtub model
7. Statistical/empirical models (Vollenweider loading criterion; Eutromod)
8. Special topics (as time permits: embayment modeling, uncertainty, trend analysis)

## Useful Internet and E-mail Addresses

### US EPA (WASP5)

Center for Exposure Assessment Modeling (Athens, GA)

[ftp://ftp.epa.gov/epa\\_ceam/wwwhtml/ceamhome.htm](ftp://ftp.epa.gov/epa_ceam/wwwhtml/ceamhome.htm)

### US Army Corps of Engineers

Waterways Experiment Station (Vicksburg, MS)

<http://www.wes.army.mil/Welcome2.html>

*Bathtub Model:* contact Dr. Robert Kennedy at: [kennedr@ex1.wes.army.mil](mailto:kennedr@ex1.wes.army.mil)

### Eutromod

North American Lake Management Society (NALMS)

<http://www.nalms.org/bkstore/bkstore.htm>

K. Reckhow

[http://www2.ncsu.edu/ncsu/CIL/WRRI/ken's\\_page.html](http://www2.ncsu.edu/ncsu/CIL/WRRI/ken's_page.html)

[ken\\_reckhow@ncsu.edu](mailto:ken_reckhow@ncsu.edu)

[reckhow@duke.edu](mailto:reckhow@duke.edu)

### General

Old Dominion University, Department of Civil and Environmental Engineering

(Dr. Jaewan Yoon)

<http://www.cee.odu.edu/cee/model/model.html>

## Model Selection Criteria

- the model is appropriate and comprehensive
- prediction uncertainty is acceptable
- cost and ease of use are reasonable

## Model Descriptors/Approaches

- *Mechanistic (process oriented)*

Conservation of mass (mass balance):

$$\text{Accumulation} = \text{Inputs} - \text{Outputs} \pm \text{Reactions}$$

$$V \frac{dP}{dt} = W - QP \pm \sigma PV$$

- *Empirical (statistical)*

Statistical (parameter) estimation (e.g., regression)

$$Chla = 0.0731P^{1.449}$$

Manage Water Quality  
in  
Lake Sunapee

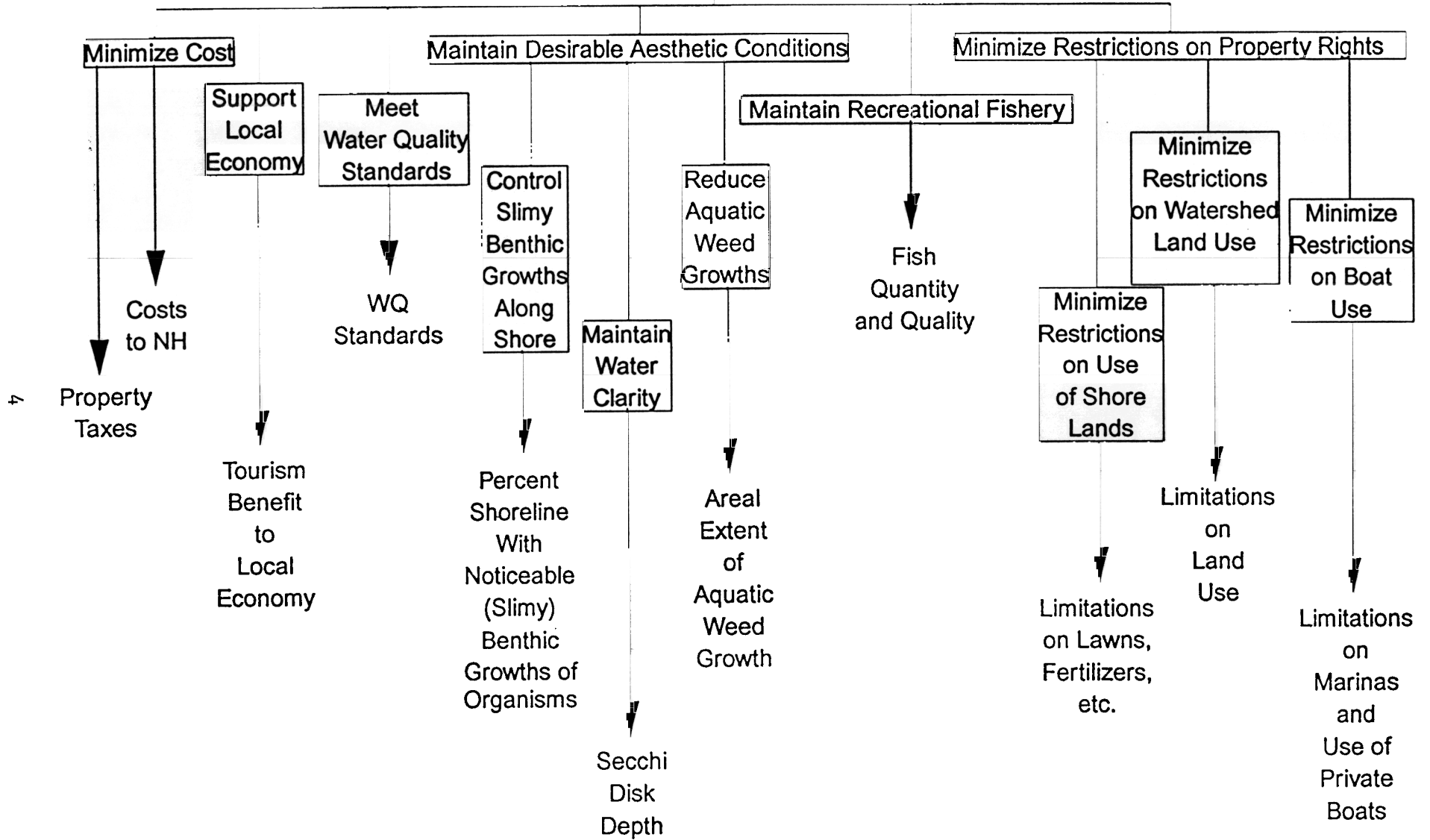

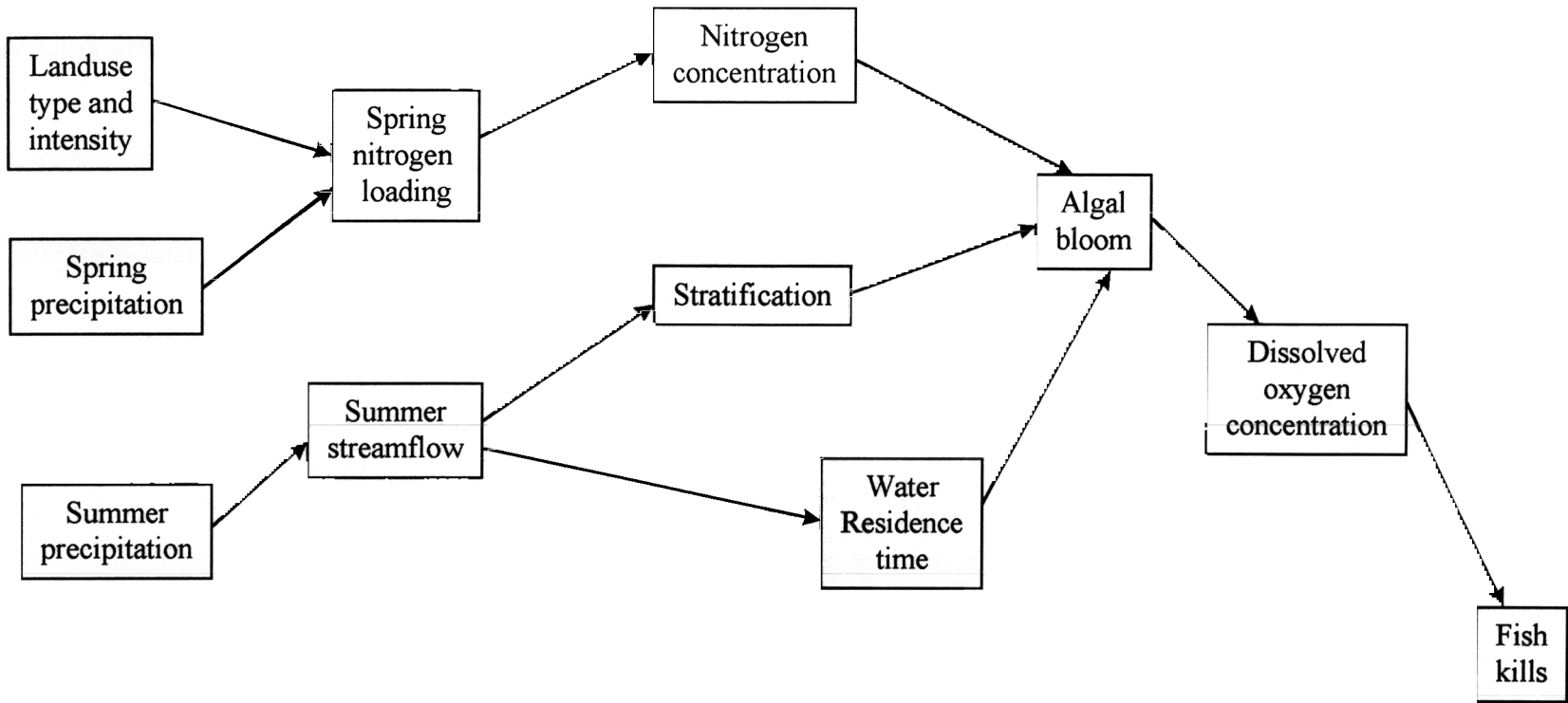

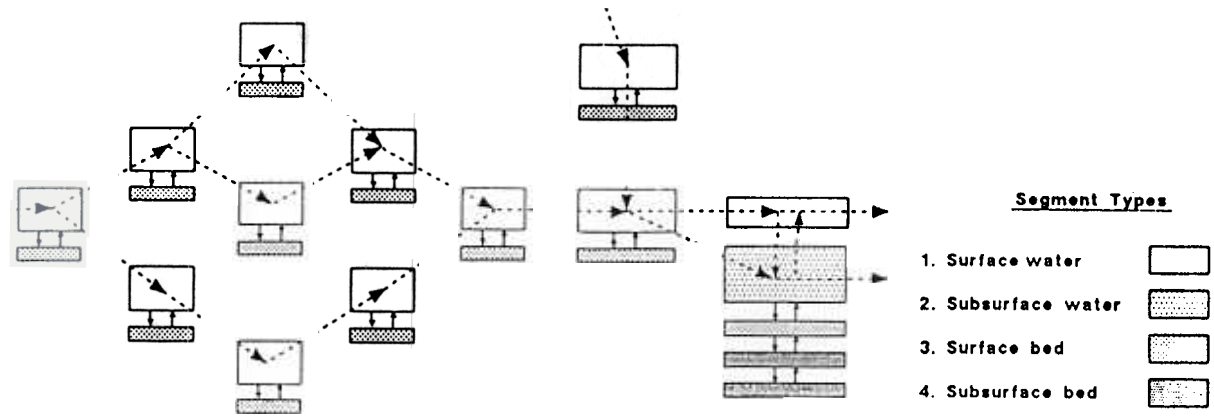
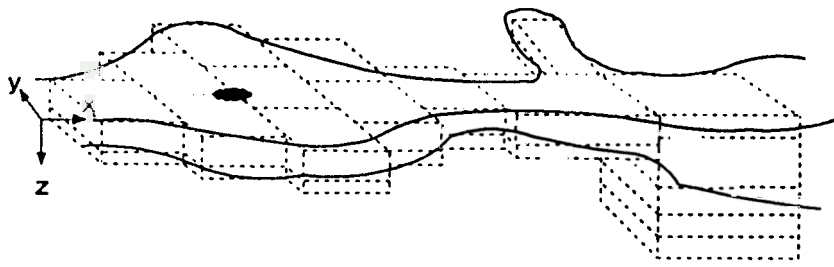

Figure 1.3.2. Model segmentation

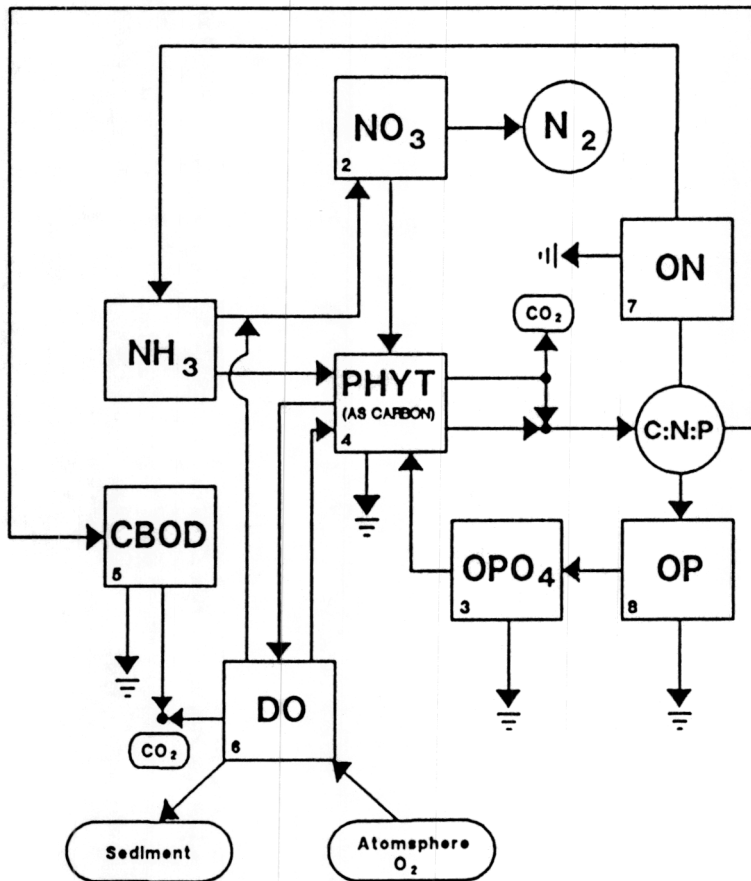

Figure 1.4.1 EUTRO4 state variable interactions

## WASP5 Phytoplankton Growth Equations

$$\text{Growth Rate} = G_{\text{max,Temp}} G_{\text{Nutrients}} G_{\text{Light}} = G_{1\text{max}}(T) G(I, t) G(N)$$

$$G_{1\text{max}}(T) = G_{1\text{max}}(20 \text{ }^\circ\text{C}) \theta_1^{(T-20)}$$

where:

$\theta_1$  = temperature coefficient, unitless

$$G(I, t) = \frac{e}{K_e D} \left[ \exp \left\{ \frac{I_o}{I_s} \exp(-K_e D) \right\} - \exp\left(-\frac{I_o}{I_s}\right) \right] \quad 1.4.6$$

where

$$I_s = \frac{G_{1\text{max}}(T) \theta_c e}{\Phi_{\text{max}} K_c f_u} \quad 1.4.7$$

where

$D$  = the average segment depth, m

$\Phi_{\text{max}}$  the quantum yield, mg carbon fixed per mole of light quanta absorbed

$K_e$  the total extinction coefficient, computed from the sum of the non-algal light attenuation,  $K_e$ , and the self-shading attenuation due to ambient phytoplankton population,  $\text{m}^{-1}$

$K_c$  the extinction coefficient per unit of chlorophyll,  $\text{m}^2/\text{mg}$  chlorophyll  $\underline{a}$

$f_u$  = units conversion factor (0.083, assuming 43% incident light is visible and 1 mole photons is equivalent to 52,000 cal) mole photons/ $\text{m}^2\text{-ly}$

$I_o$  = the incident light intensity just below the surface, assumed to average 0.9 I, ly/day

$I_s$  = the saturating light intensity of phytoplankton, ly/day

$\theta_c$  the ratio of carbon to chlorophyll in the phytoplankton, (mg carbon/mg chlorophyll  $\underline{a}$ )

$e$  = the base of natural logarithms (2.71828), unitless

$$G(N) = \text{Min} \left( \frac{\text{DIN}}{K_{mN} + \text{DIN}} \quad \frac{\text{DIP}}{K_{mP} + \text{DIP}} \right)$$

DIN, DIP = dissolved nutrient concentrations  
 $K_{mN}$ ,  $K_{mP}$  = Michael-Menten parameters



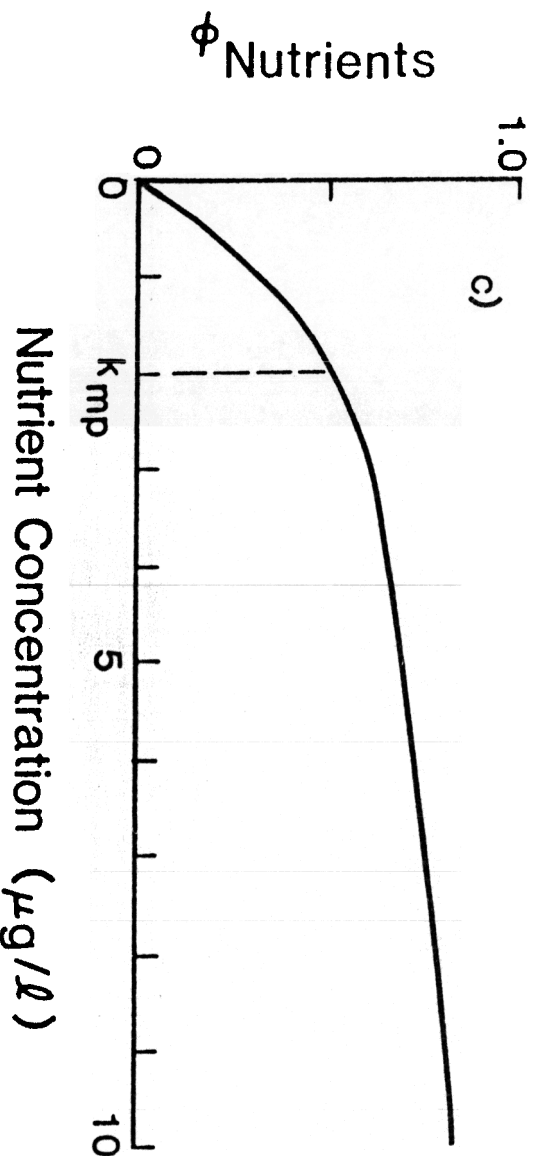
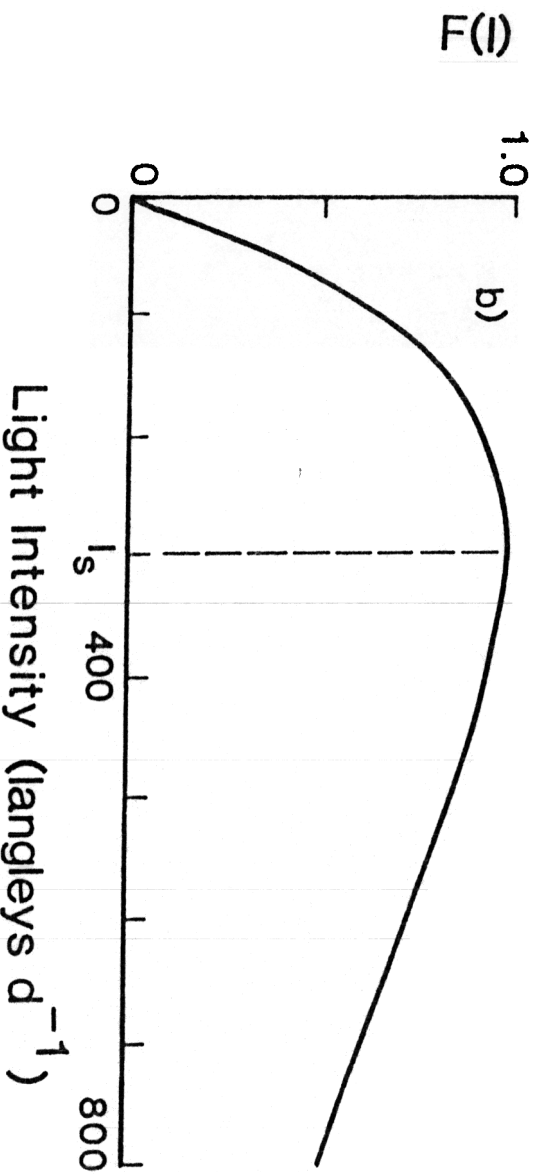
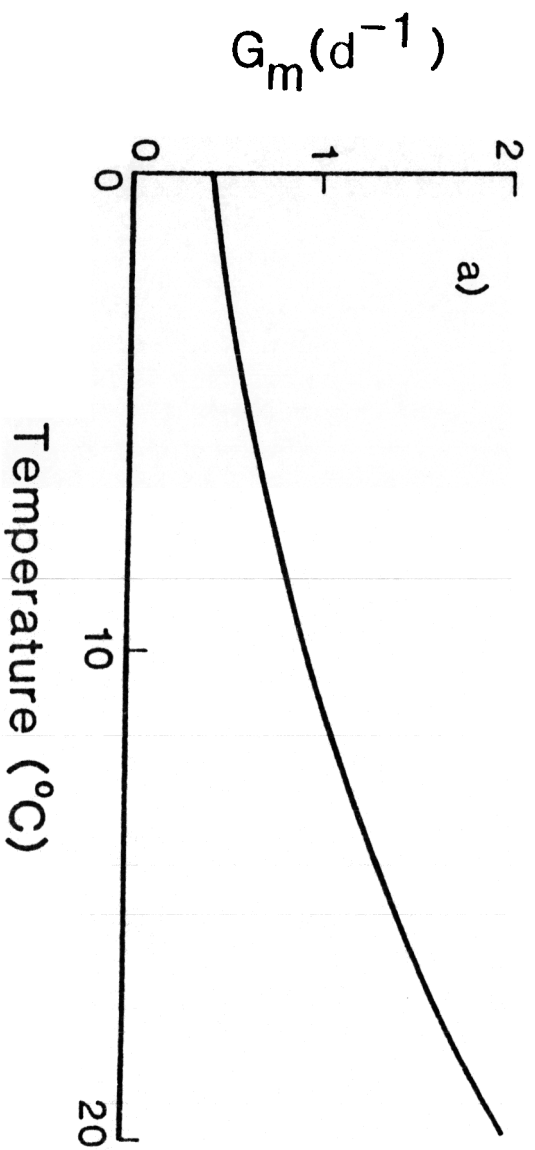

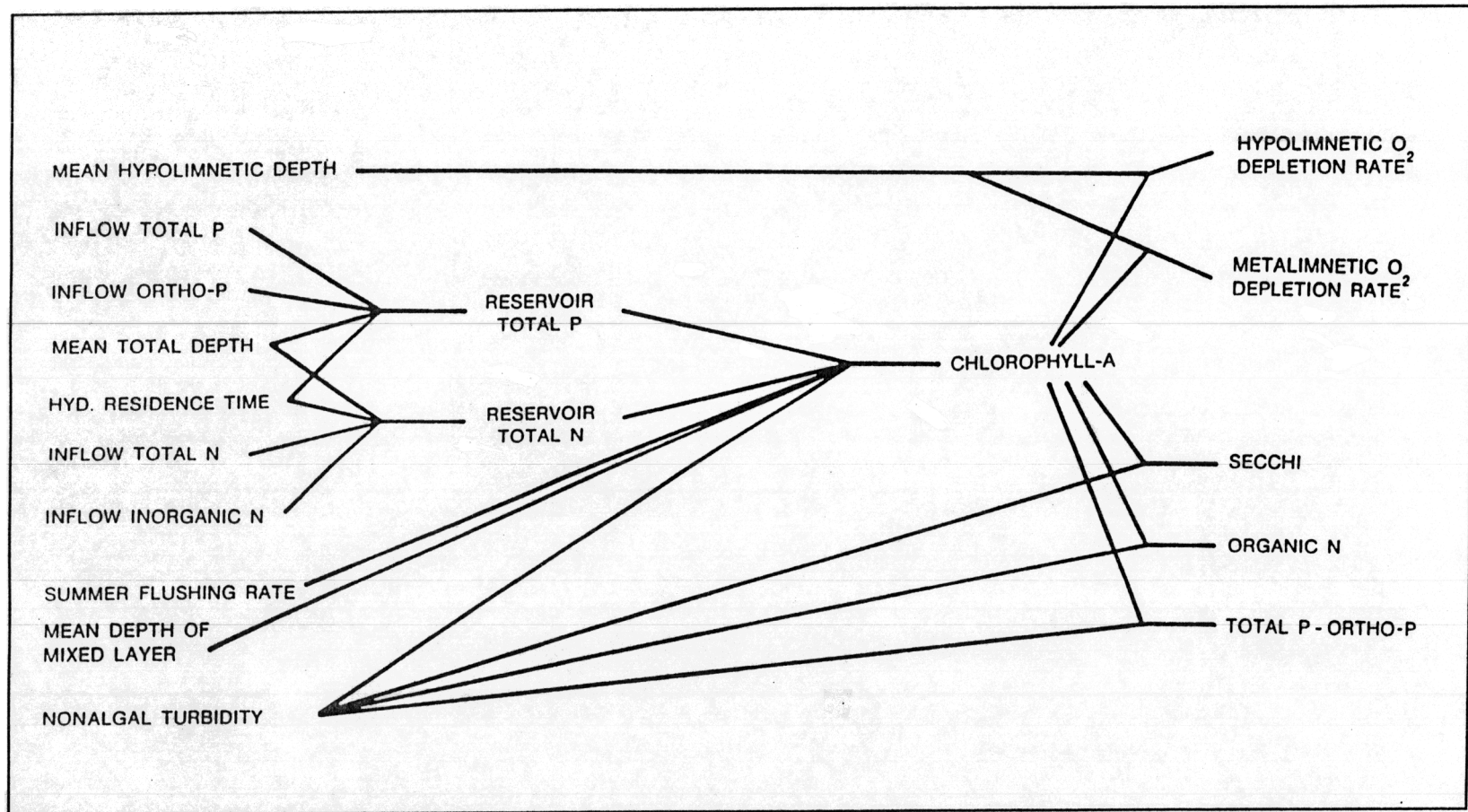

Figure 4.2. Control pathways in empirical eutrophication models developed for CE reservoir applications

SCHEME 1.

SINGLE RESERVOIR, SPATIALLY AVERAGED



SCHEME 2.

SINGLE RESERVOIR, SEGMENTED

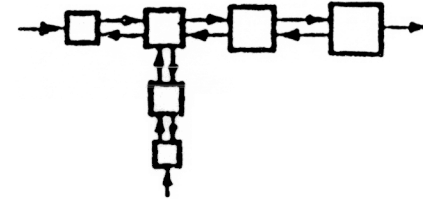

SCHEME 3.

PARTIAL RESERVOIR OR EMBAYMENT, SEGMENTED



SCHEME 4.

SINGLE RESERVOIR, SPATIALLY AVERAGED,

MULTIPLE LOADING REGIMES

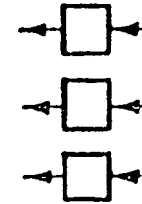

SCHEME 5.

COLLECTION OF RESERVOIRS, SPATIALLY AVERAGED

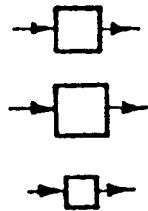

SCHEME 6.

NETWORK OF RESERVOIRS, SPATIALLY AVERAGED

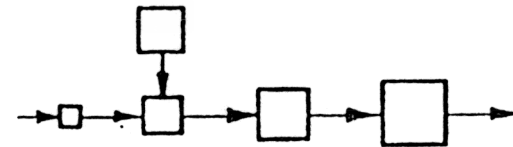

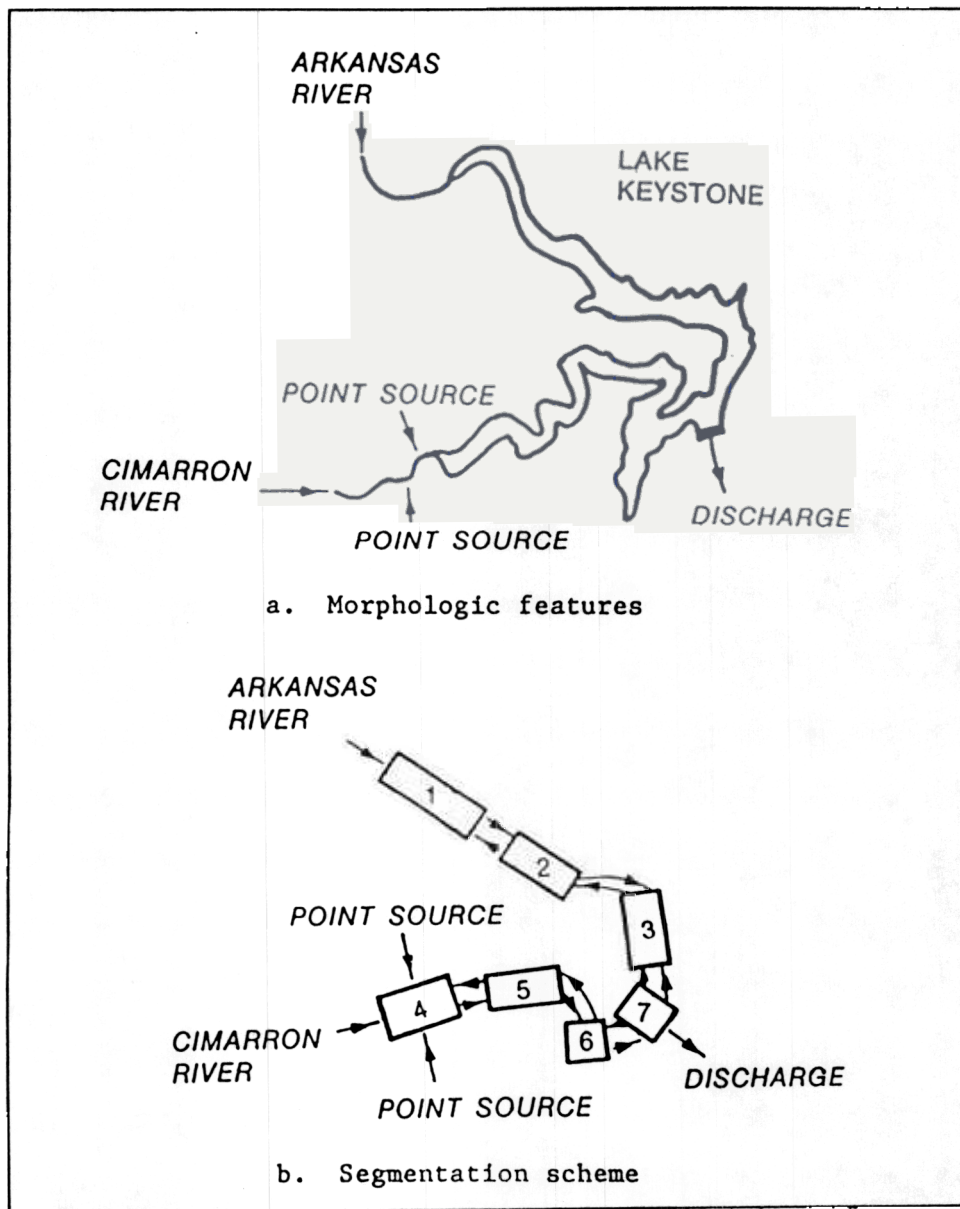

Figure 4.9. Model segmentation for Lake Keystone, Oklahoma, application

## BATHTUB Chlorophyll Equations

**Model 1: N, P, Light, Flushing Rate**

$$X_{pn} = [P^{-2} + ((N-150)/12)^{-2}]^{-0.5}$$

$$B_x = X_{pn}^{1.33} / 4.31$$

$$G = Z_{mix} (0.14 + 0.0039 F_s)$$

$$B = CB B_x / [(1 + 0.025 B_x G) (1 + G_a)]$$

**Model 2: P, Light, Flushing Rate [default]**

$$B_p = p^{1.37} / 4.88$$

$$G = Z_{mix} (0.19 + 0.0042 F_s)$$

$$B = CB B_p / [(1 + 0.025 B_p G) (1 + G_a)]$$

**Model 3: P, N, Low-Turbidity**

$$B = CB 0.2 X_{pn}^{1.25}$$

**Model 4: P, Linear**

$$B = CB 0.28 P$$

**Model 5: Jones and Bachman (1976)**

$$B = CB 0.081 P^{1.46}$$

where:

B = chlorophyll *a* concentration (ug/l)

P = total phosphorus concentration (ug/l)

N = total nitrogen concentration (ug/l)

CB = calibration factor for chlorophyll *a*

Z<sub>mix</sub> = mean depth of mixed layer (m)

F<sub>s</sub> = summer flushing rate (yr<sup>-1</sup>)

a = nonalgal turbidity (m<sup>-1</sup>)

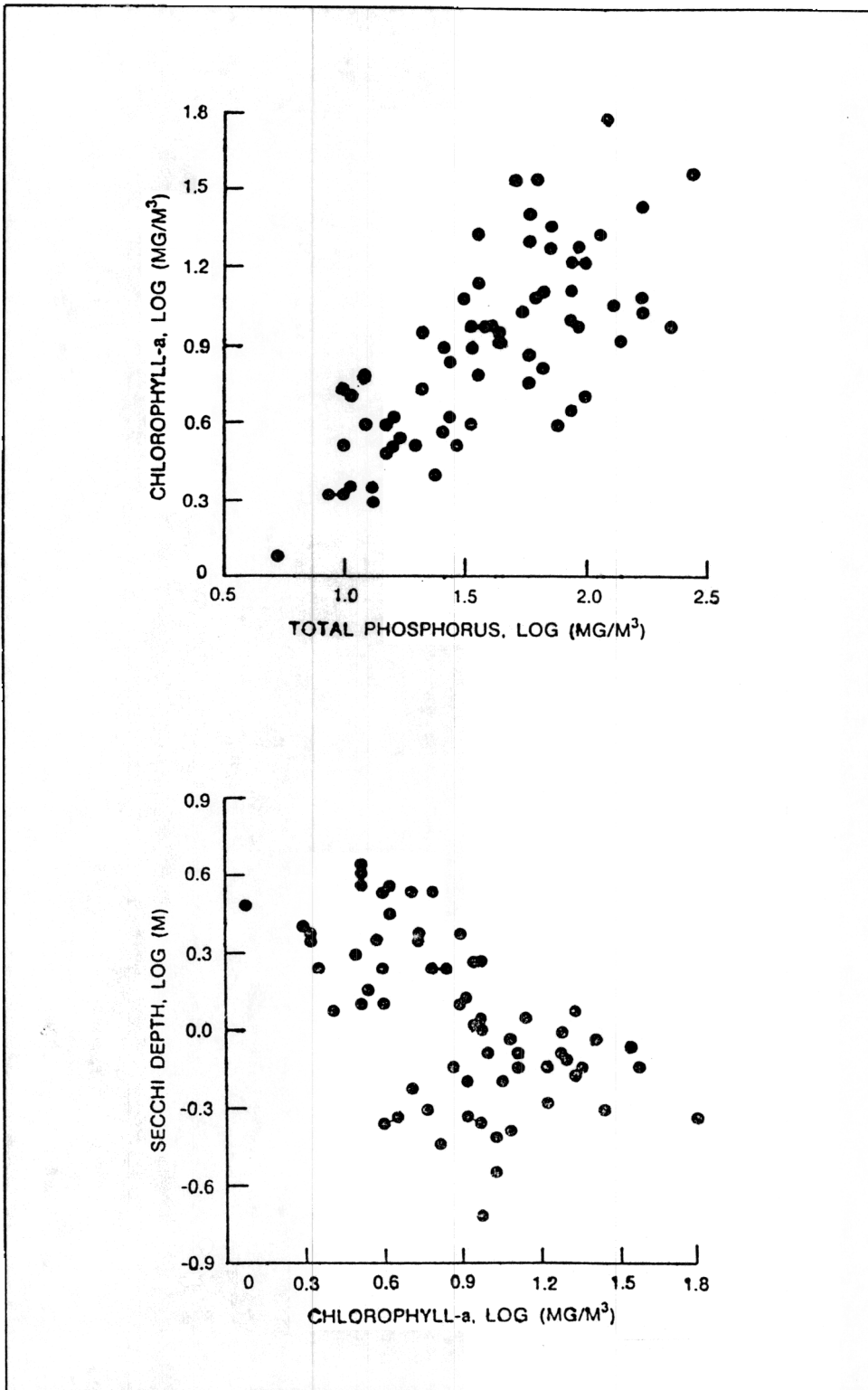

Figure 4.7. Phosphorus, chlorophyll *a*, and transparency relationships for CE reservoirs

FIG. 8. Chlorophyll and Total Phosphorus Concentrations in the Lake Okeechobee Littoral Zone (May - October Data).

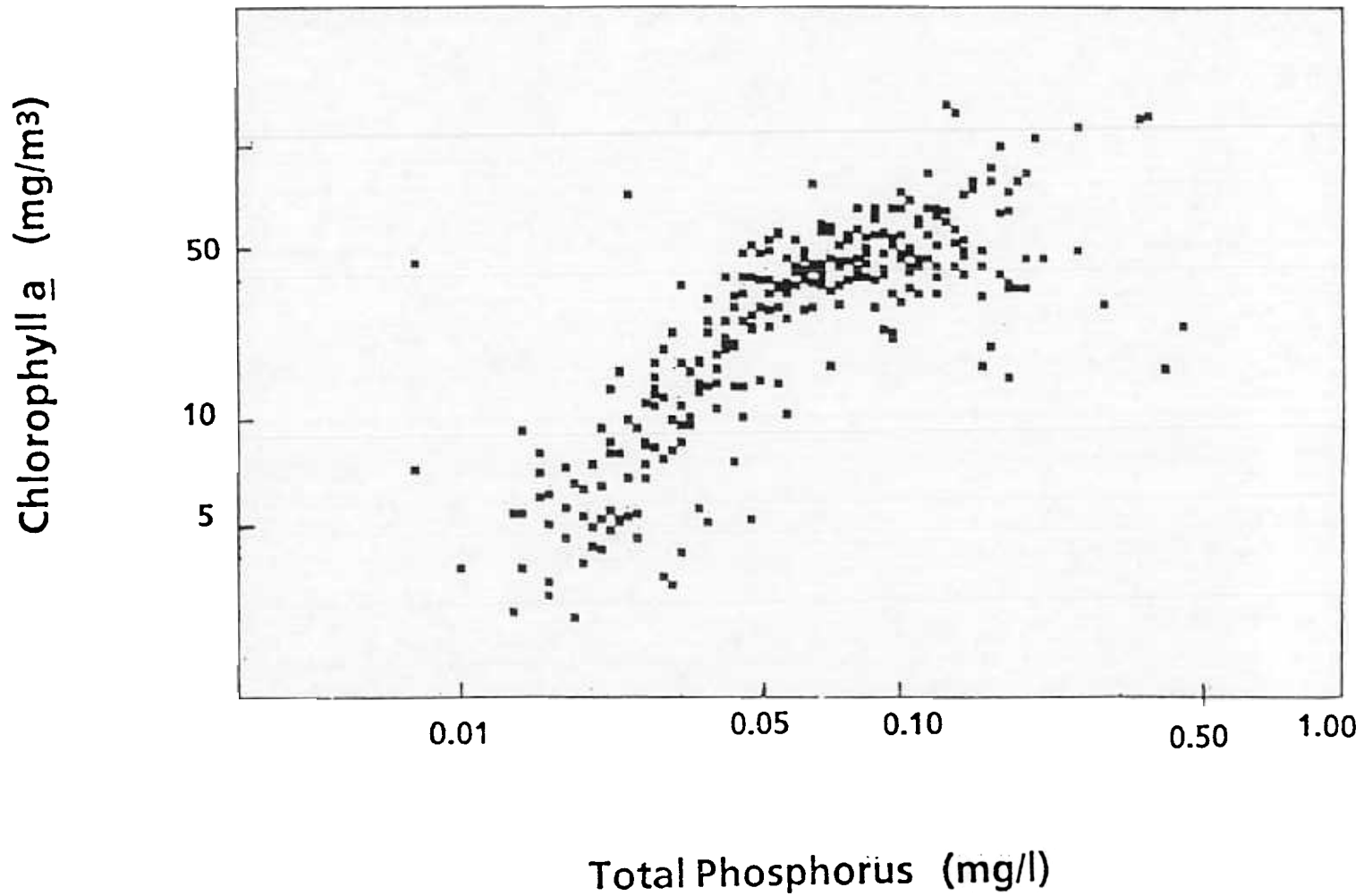
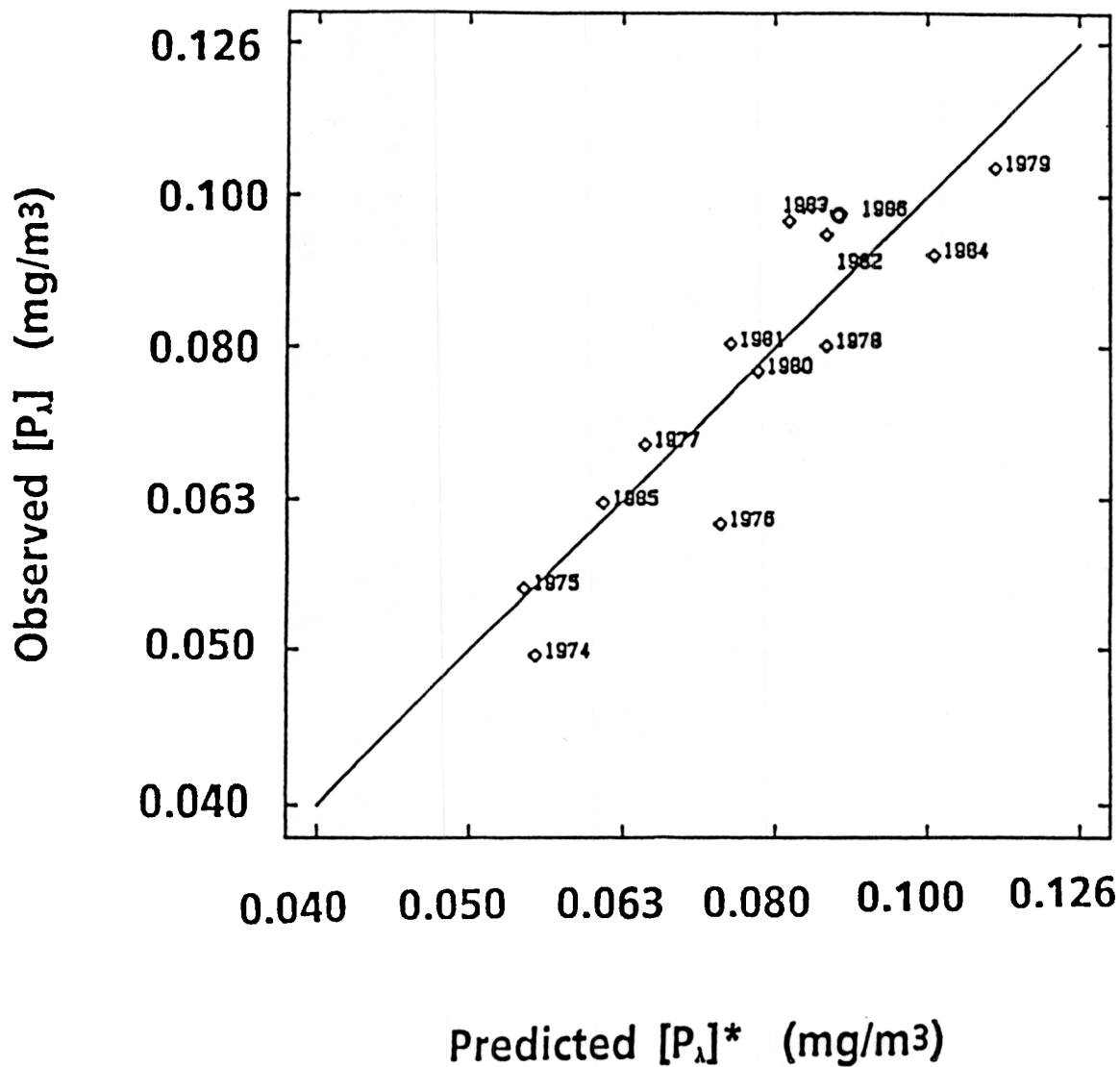

FIG. 3. Next year's mean lake [P] as a function of ( $P_i, T_w, z$ ) for Okeechobee.



\*i.e., predicted from the three-factor multiple regression model



$$\text{Chl } a = 0.0731P^{1.449}$$

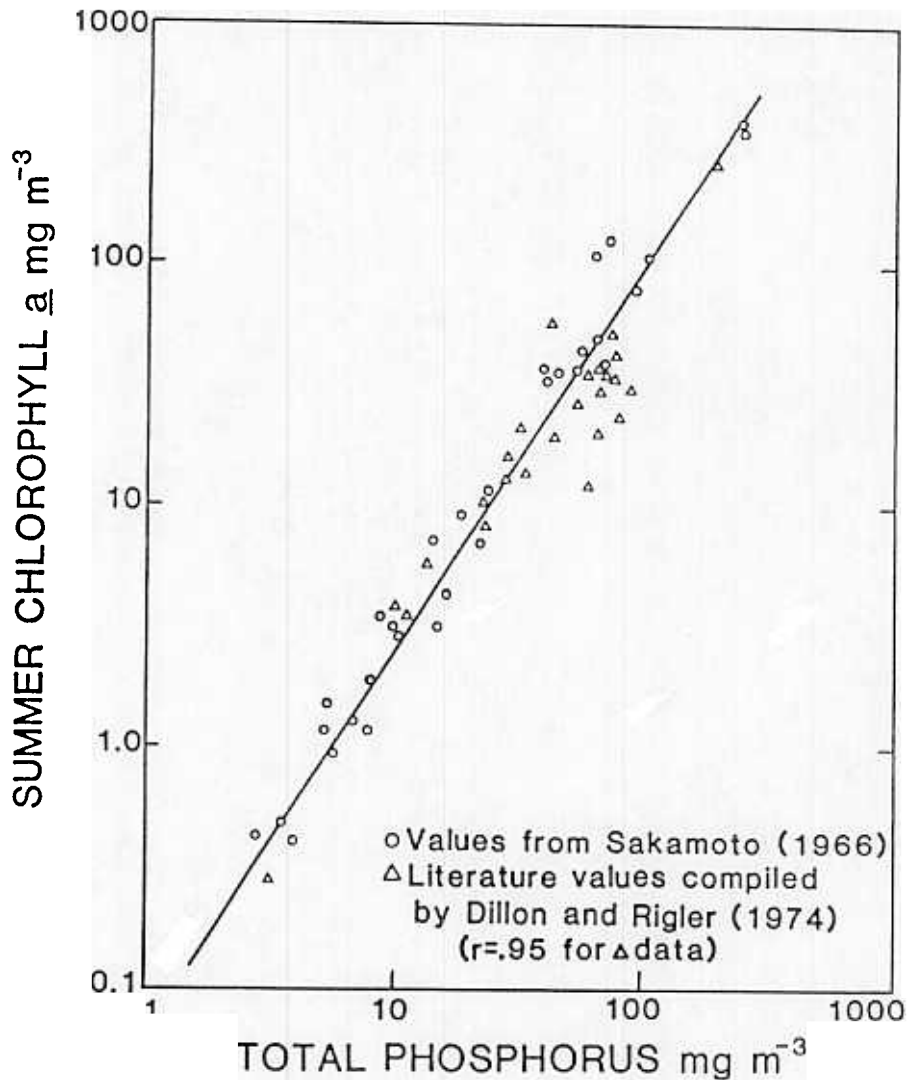

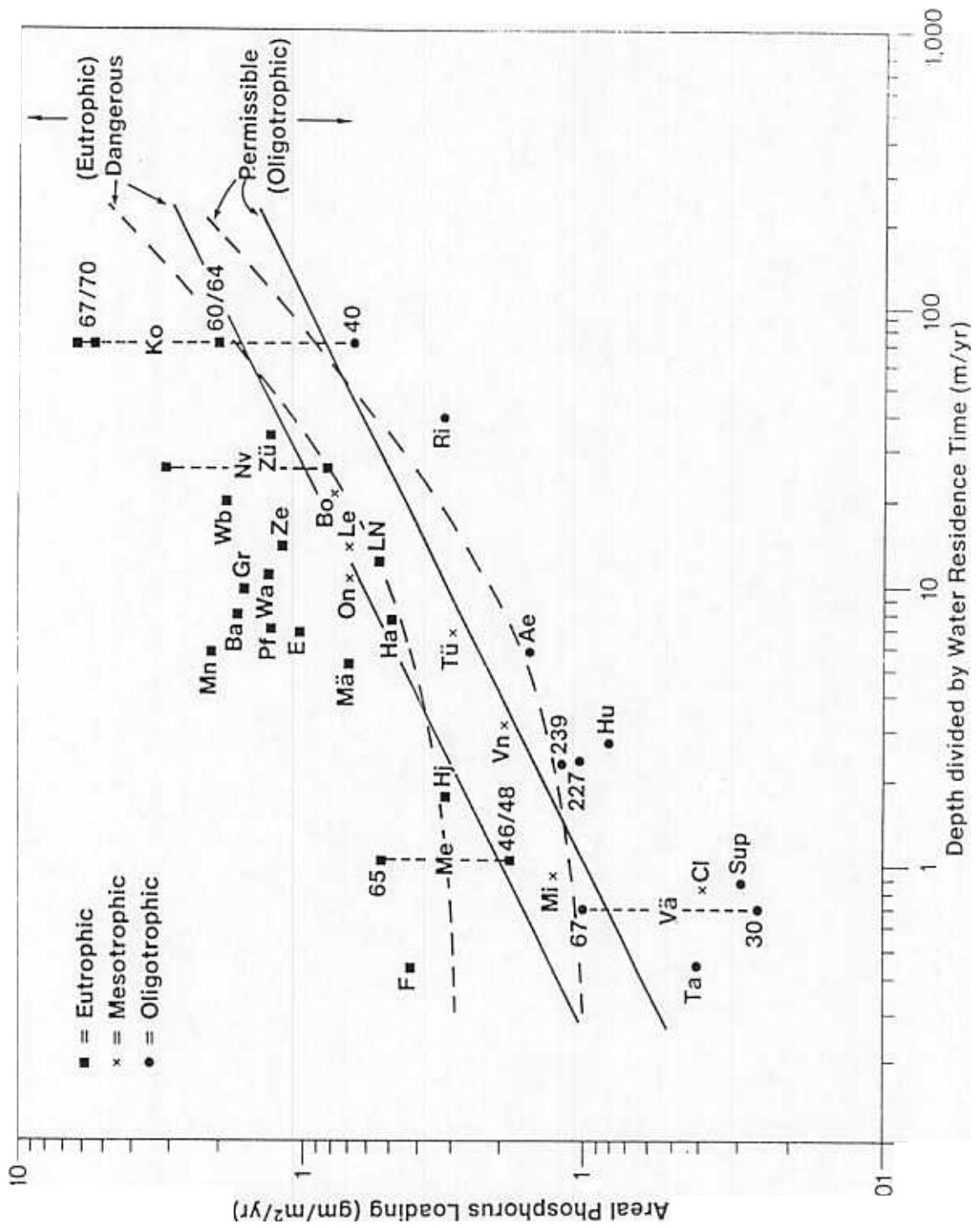

# Lake Models

## Input-Output Models for Nutrients

Mass balance (conservation of mass):

Accumulation = Inputs - outputs ± Reactions

for phosphorus:

$$V \frac{dP}{dt} = W - QP - kPV$$

solution:

$$P = \frac{W}{Q+kV} \left[ 1 - e^{-\left(\frac{1}{\tau}+k\right)t} \right] + P_i e^{-\left(\frac{1}{\tau}+k\right)t}$$

steady-state solution:

$$P = \frac{W}{Q+kV} = \frac{P_{in}}{1+k\tau}$$

other similar expressions:

$$P = \frac{L}{v_s+q_s} = P_{in}(1 - R_p)$$

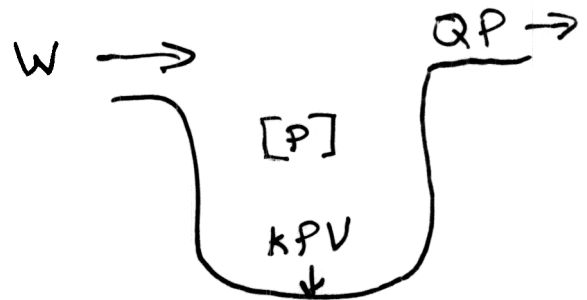

<p>V=lake volume  P=phosphorus concentration  W=phosphorus mass loading  Q=volumetric water load  k=first order reaction rate</p> <p><math>\tau</math>=water residence time  <math>P_{in}</math>=influent p-concentration  <math>v_s</math>=apparent settling</p>
---

## Eutromod Equations for Arkansas Lakes

### Total Phosphorus (mg/l)

$$\log_{10}(P) = \log_{10} \left[ \frac{P_{in}}{1 + k\tau} \right]$$

$$\text{where: } k = 10.77\tau^{-0.61}z^{0.01}P_{in}^{0.82}$$

### Total Nitrogen (mg/l)

$$\log_{10}(N) = \log_{10} \left[ \frac{N_{in}}{1 + k\tau} \right]$$

$$\text{where: } k = 0.46\tau^{-0.75}z^{0.22}N_{in}^{0.95}$$

### Chlorophyll a (ug/l)

$$\log_{10}(chla) = 1.99 + 0.51\log_{10}(\hat{P}) + 0.23\log_{10}(\tau) - 0.351\log_{10}(z)$$

### Secchi Disk Depth (m)

$$\log_{10}(SD) = -1.32 - 0.66\log_{10}(\hat{P}) + 0.47\log_{10}(z)$$

where:

$\tau$  = water residence time

$z$  = mean depth

$\hat{\sim}$  "predicted"

$in \sim$  influent

EUTROMOD  
Version 2.50  
by  
Kenneth H. Reckhow  
Duke University  
Durham, NC 27706  
1991

A watershed/lake modeling procedure for eutrophication  
management, with region-specific models and  
with emphasis on uncertainty analysis.

Enter two letter (all caps) state postal code (e.g., NY)  
in box, identifying the location of the lake.

CO

Hit ALT-X to continue; this selects the region-specific lake models.

Figure A.

**Eutromod:  
Map of Screen Worksheets**

	A	J	T	AB
20	Surface water runoff Precipitation USLE	USLE	Land areas Septic tanks Treatment plants	Lake depth Detention time, etc. Water runoff
40	Phosphorus concentrations in inputs	Nitrogen concentrations in inputs	Attenuation zones for nutrient trapping	Calculation tables
60	Phosphorus- total loading by land use category	Nitrogen- total loading by land use category	Attenuation zones for nutrient trapping	Calculation tables
80	Lake response predictions (uncertainty due to hydrologic variability)	Lake response predictions (uncertainty due to model error)	Attenuation zones for nutrient trapping	Calculation tables
100	Allowable nutrient loading (chlor a goal)	Allowable nutrient loading (chlor a, P goals)	Calculations- dissolved nutrients	
120	Allowable nutrient loading (TSI goal)		Calculations- sediment-attached nutrients	
140			Calculations- total nutrients	

<sup>1</sup> Letters across the top of the table and numbers along the left side identify cells in the spreadsheet (e.g., the intersection of "T" and "60" is cell T60).

Figure A.2

Surface Water Runoff & Soil Loss

Figure A.3

Universal Soil Loss Equation

Land Use Category	LS factor	C factor	P factor	Xi
Agriculture1	0.3	0.2	0.5	5.263
Agriculture2	0.4	0.03	0.3	0.631
Agriculture3	0	0	0	0
Agriculture4	0	0	0	0
Agriculture5	0	0	0	0
Forest	0.9	0.001	0.2	0.031
Urban1				0
Urban2				0
Feedlots				0
Other1	0	0	0	0
Other2	0	0	0	0
Other3	0	0	0	0

X (total soil loss) =2.12098961 t/ha (area-weighted average)

Figure A.6

Phosphorus Concentration Estimates  
Dissolved and Total in mg/l; Sed-Attached (Ci) in mg/kg]

Land Use Category	Dissolved	Sed-Attach	Total
Agriculture1	0.07	220	*****
Agriculture2	0.07	220	*****
Agriculture3	0	0	*****
Agriculture4	0	0	*****
Agriculture5	0	0	*****
Forest	0.008	220	*****
Urban1	*****	*****	0.2
Urban2	*****	*****	0.1
Feedlots	*****	*****	0
Other1	0	0	*****
Other2	0	0	*****
Other3	0	0	*****
Precipitation	*****	*****	0.05

P-enrichment ratio = 2

Figure A.7

Nitrogen Concentration Estimates  
[Dissolved and Total in mg/l; Sed-Attached (Ci) in mg/kg]

Land Use Category	Dissolved	Sed-Attach	Total
Agriculture1	2.8	500	*****
Agriculture2	1.8	500	*****
Agriculture3	0	0	*****
Agriculture4	0	0	*****
Agriculture5	0	0	*****
Forest	0.19	500	*****
Urban1	*****	*****	1.5
Urban2	*****	*****	1.75
Feedlots	*****	*****	0
Other1	0	0	*****
Other2	0	0	*****
Other3	0	0	*****
Precipitation	*****	*****	0.1

N-enrichment ratio = 2



Phosphorus Loading Estimates - By Category

Loading (kg/yr)	Expected
Agriculture	546.93439
Forest	7.2419592
Urban	19.635
Feedlots	0
Precipitation	37.6635
Septic Tanks	24.375
Point Sources	0
Other	0

Estimated Total = 635.849855 (kg/yr)

Nitrogen Loading Estimates - By Category

Loading (kg/yr)	Expected
Agriculture	9847.0767
Forest	145.88448
Urban	158.6865
Feedlots	0
Precipitation	75.327
Septic Tanks	216.125
Point Sources	0
Other	0

Estimated Total = 10443.0997 (kg/yr)

Predicted Lake Trophic State Variables - Based on Model Uncertainties  
(Median Values)

Variable (units)	-1 Std Err	Predicted	+1 Std Err
Total P-in (mg/l)		0.0805	
Total N-in (mg/l)		1.3226	
Total P (mg/l)	0.0259	0.0387	0.0577
Total N (mg/l)	0.6860	0.8899	1.1544
Chlor a (ug/l)		12.7905	
Secchi Depth (m)	1.4660	1.0826	0.8282
Prob Hypo Anoxia		0.3964	
Prob BG Dominant		0.5187	
THMs			
TSI			